

Notice de montage / Bout dehors Sparcraft

1. Composants du kit / Outils nécessaires

Liste composants du kit standard



- section équipée d'un collier central + embouts avant & arrière
- 2 plots de travail + 4 vis M8 + contre-plaque
- 1 plot de repos + 1 vis M10 + contre-plaque ronde



Liste des outils nécessaires



- perceuse
- clés allen BTR 5 & 6
- forets Ø8.5 & Ø10.5mm
- fraise à chanfreiner
- cliquet (douilles Ø 10.7 & Ø13mm)
- silicone

2. Plan d'ensemble (exemple) / Marquage longueur dehors max

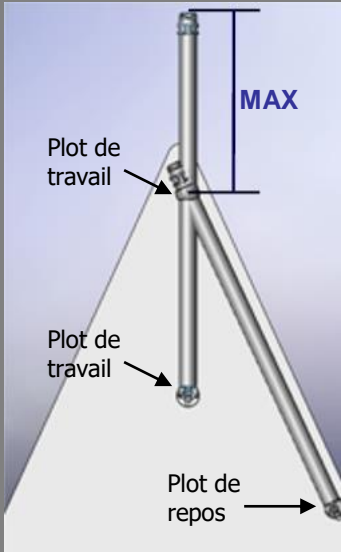

Longueur utile maximum :

Ø section bout dehors	Longueur utile maximum
70mm	800mm
80mm	900mm
90mm	950mm
100mm	1000mm

Surface voile maximum

Lg bateau	Ø section bout dehors	Surface max spi asymétrique	Surface max gennaker*
25'-36'	70mm	60m ²	37m ² *
36'-40'	80mm	82m ²	52m ² *
40'-47'	90mm	102m ²	65m ² *
48'-57'	100mm	130/150m ² *	105m ² *

* avec utilisation d'une sous-barbe

Marquage longueur dehors max (cf tableau ci-contre)



Mesurer



Marquer



3. Repérage sur le pont de l'emplacement du bout dehors et des plots et sous le pont également

A

B

C

D

E

Repérer

Vérifier emplacement & fixation des plots de travail+repos sur et sous le pont

Marquer

4. Fixation du plot de travail avant

Foret Ø8.5mm

Fraise Ø10.7mm

Silicone

Clé allen BTR 5 + cliquet

A

B

C

D

E

Percer

Chanfreiner

Nettoyer & étanchéifier

Visser

Vérifier

5. Fixation du plot de travail arrière (même procédure de montage que le plot de travail avant, cf §3.)

6. Fixation du plot de repos



Percer



Chanfreiner



Nettoyer & Etanchéfier



Visser



Vérifier

7. Montage terminé (exemple sur un First 36.7)



Position travail



Position repos



8. Options et accessoires

Option adaptation davier

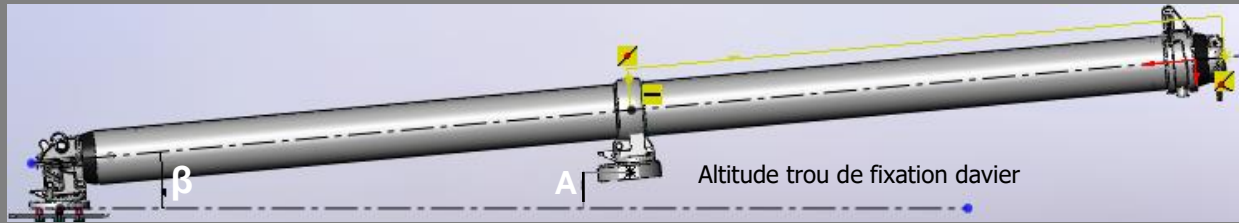

	BDH 70	BDH 80	BDH 90	BDH 100
Longueur utile	800mm	900mm	950mm	1000mm
β = Angle maxi	5°	5°	3.15°	3.15°
A = Altitude trou de fixation davier	38,5mm	53,5mm	28mm	31mm

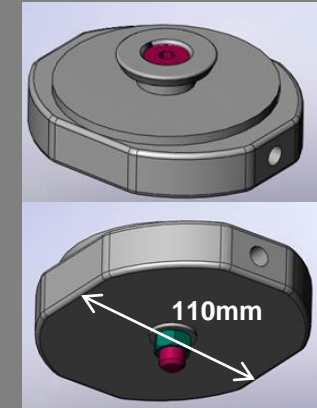

Semelle davier livrée pré-montée

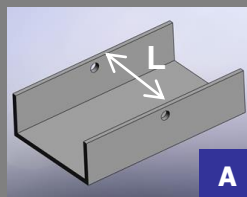

Mesurer

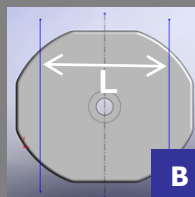

Couper

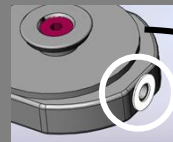

Positionner

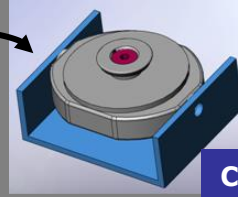

Visser

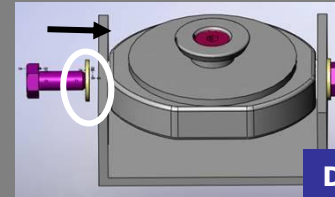

Incliner

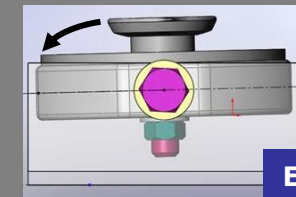

Sécuriser

NB : Possibilité de mettre une cale sous le champignon travail arrière pour que la position du trou de fixation davier soit plus haute.

Option bague d'amure / fixation emmagasineur

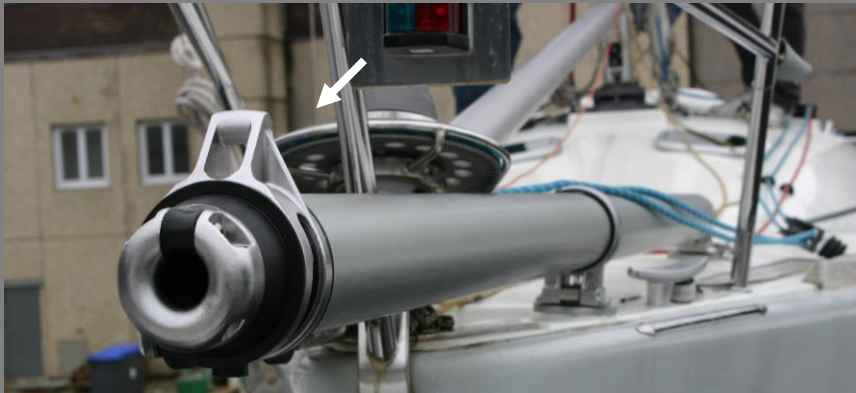

Accessoire : protection plot



Installation notes / Sparcraft Bowsprit

1. Kit components / Tools needed for assembly

List of standard kit components



- section with central collar & end fittings
- 2 working deck plates + 4x M8 screws + reinforcing plates



- 1 parking deck plate + 1x M10 screw + round reinforcing plates



List of needed tools for assembly



- drill
- BTR 5 & 6 allen keys
- Ø8.5 & Ø10.5mm drill bits
- chamfer mills
- torque driver (socket drive Ø 10.7 & Ø13mm)
- silicone

2. Assembly drawing (example) / Marking the maximum outside length

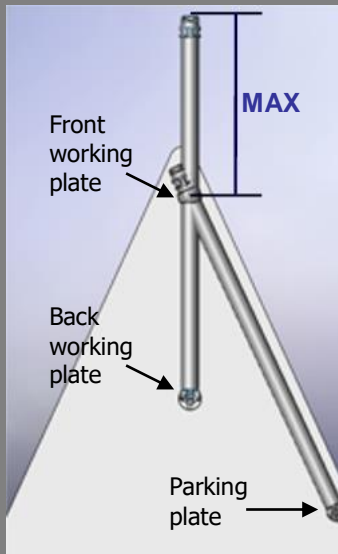

Maximum outside length :

Ø bowsprit section	Longueur utile maximum
70mm	800mm
80mm	900mm
90mm	950mm
100mm	1000mm

Maximum sail area

Boat length	Ø bowsprit section	max asymmetric Spinnaker area	Max Gennaker area*
25'-36'	70mm	60m ²	37m ² *
36'-40'	80mm	82m ²	52m ² *
40'-47'	90mm	102m ²	65m ² *
48'-57'	100mm	130/150m ² *	105m ² *

Marking the maximum outside length (see chart against)



Measure



Mark with sellotape

3. Measure on deck and under deck to valid bowsprit position

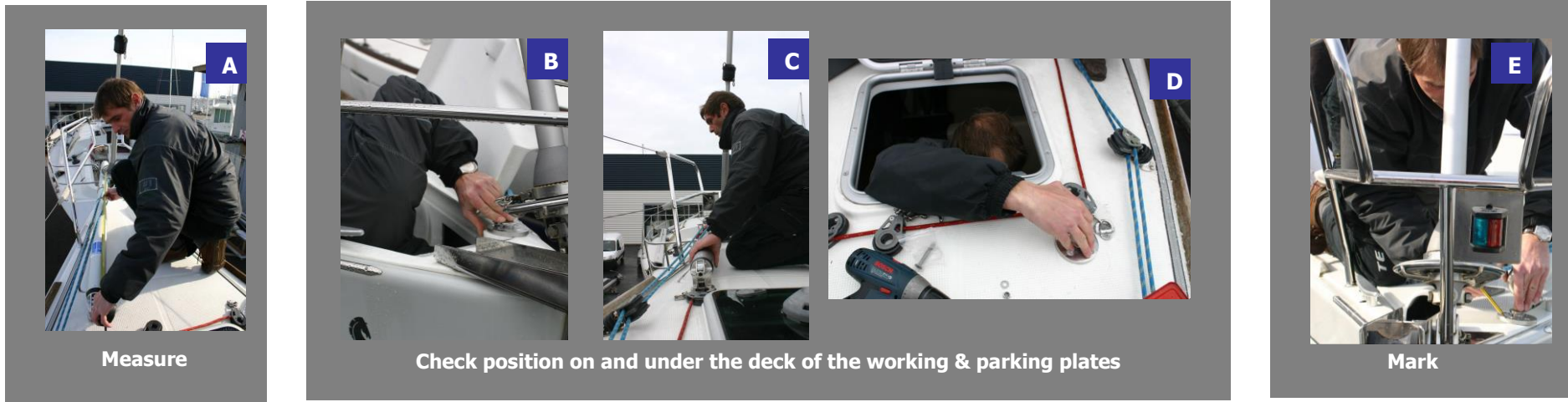

4. Fixing the front working plate

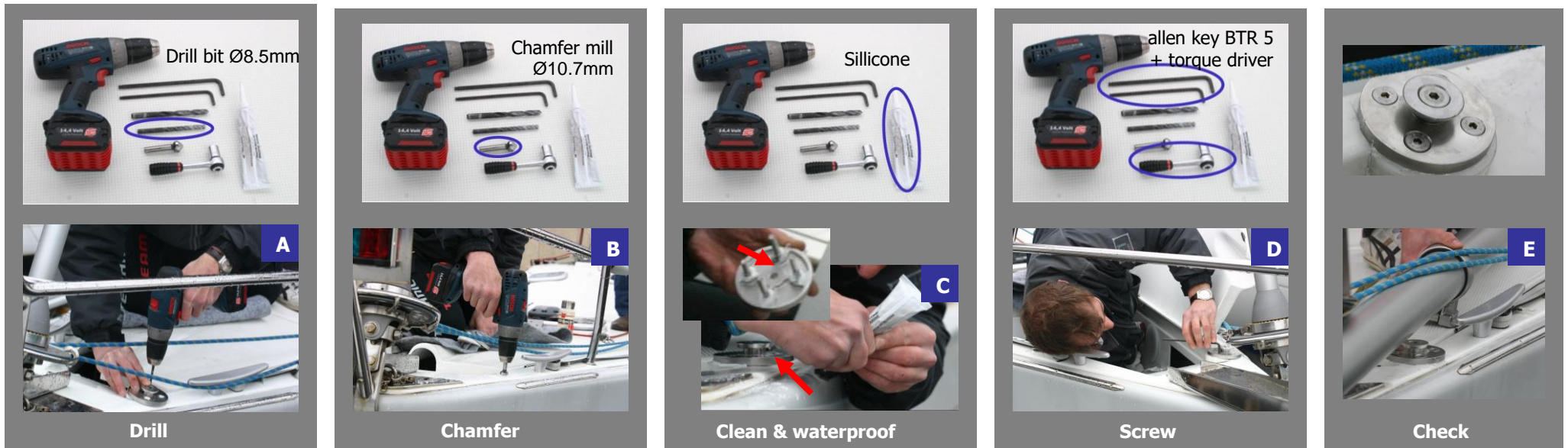

5. Fixing the back working plate (same instructions as the §3.)

6. Fixing the parking plate

<p>Drill bit Ø10.5mm</p>	<p>Chamfer mill Ø13mm</p>	<p>Silicone</p>	<p>allen key BTR 6 + torque driver</p>	
<p>A</p>	<p>B</p>	<p>C</p>	<p>D</p>	<p>E</p>
<p>Drill</p>	<p>Chamfer</p>	<p>Clean & waterproof</p>	<p>Screw</p>	<p>Check</p>

7. Installation is over (example on board of an First 36.7)

			<p>Picture of under deck fitting</p>
<p>Working position</p>	<p>Parking position</p>		

8. Options et accessories

Stem adaptation option

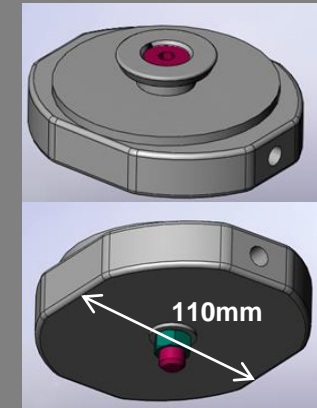
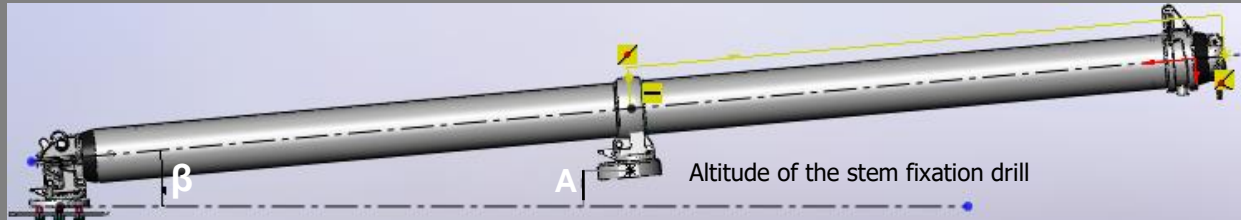

Stem plate delivered pre-fitted

	BDH 70	BDH 80	BDH 90	BDH 100
Outside length	800mm	900mm	950mm	1000mm
β = maximum angle	5°	5°	3.15°	3.15°
A = Altitude of the stem fixation drill	38,5mm	53,5mm	28mm	31mm

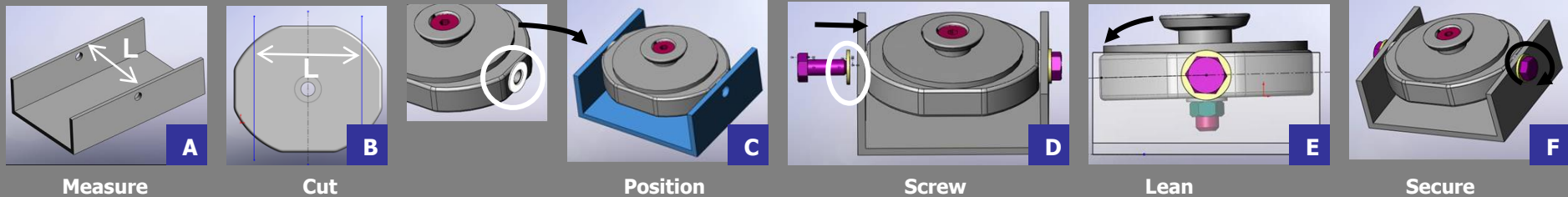

Nota: It is possible to fit extra plate underneath the back working plate in order to make it higher.

Option for fitting the Gennaker/Code Zero/Asummetric Spinnaker furler

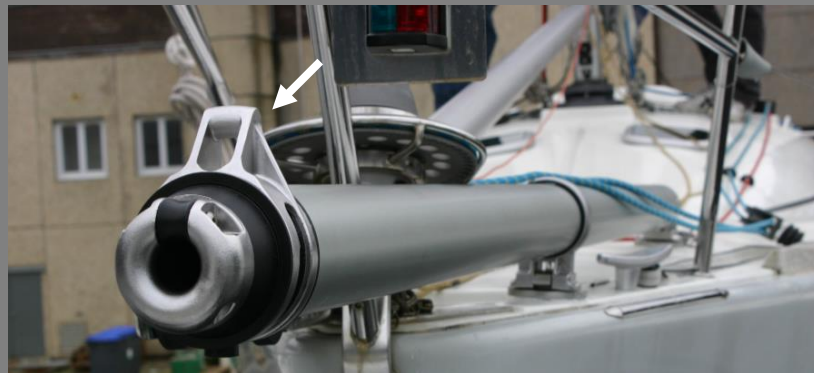

Accessory : plate cover

