

**1 – VÉRIFICATION DU COLIS**



**A : Les kits**



+ Notice à conserver pour l'utilisateur

**B : outils nécessaires**  
(non fournis)

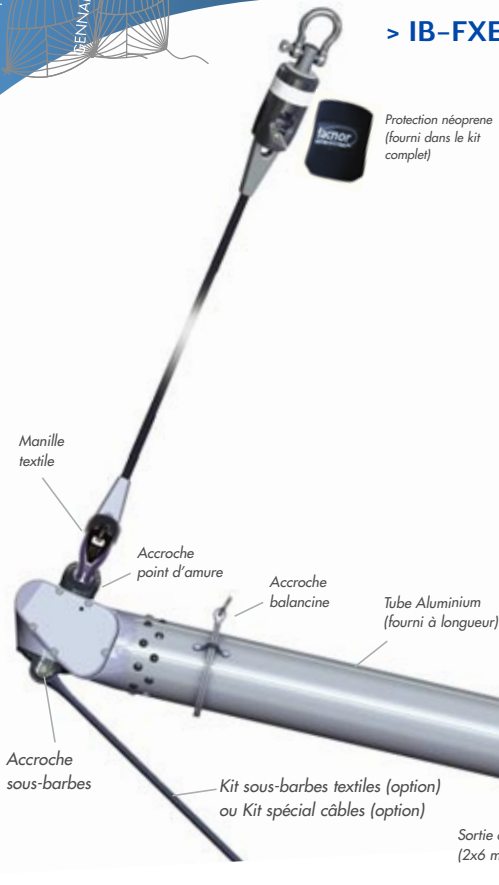
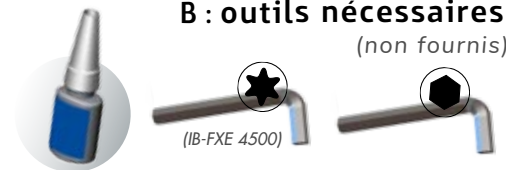

**C : Les options**

	<b>Radiocommande*</b>
	<b>Commande filaire*</b>
	<b>Cosse Fast 4500 7000</b>
	<b>Poulie de mouflage LB4T5 LB7T</b>
	<b>Accroche sous-barbes + câbles métalliques</b>
	<b>Kit Estropes pour sous-barbes textiles</b> x2

- PRÉCAUTION :**
- Ne pas faire traîner le câble électrique au risque de l'endommager. Ne pas immerger le câble électrique dans l'eau de mer
  - \* **Radio commande & Télécommande filaire :**
    - L'intervenant qui manipule la télécommande ou l'émetteur de la radiocommande est responsable de la manœuvre.
    - Ces commandes ne doivent être confiées qu'à un adulte responsable.
    - Ne jamais actionner les boutons de celui-ci (ni d'éventuels boutons au cockpit) lorsqu'un équipier manipule le bloc moteur.
    - Attention aux appuis intempestifs (poche par exemple).
    - Avant toute manœuvre, s'assurer que celle-ci pourra s'effectuer en sécurité.

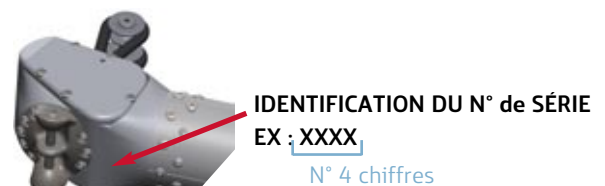

**GARANTIE**  
Le produit Facnor IB-FXe est garanti deux ans.

## A. MAINTIEN DU BOUT DEHORS ("TANGONNET")

Ajouter une retenue (balancine) de bout dehors entre le haut de la cathédrale et la manille de bout dehors.

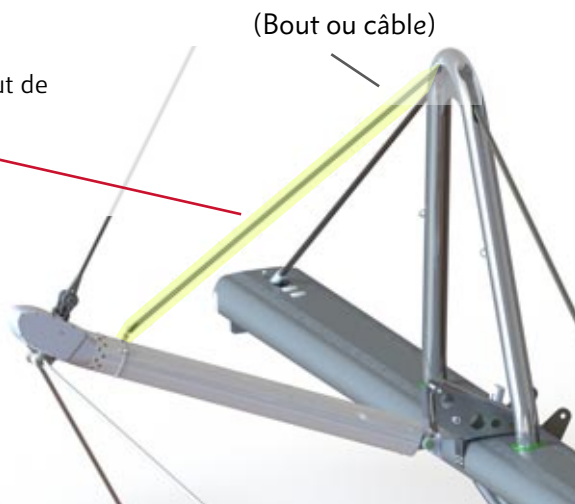

## B. CONNEXION À LA POUTRE DE CATAMARAN

Après avoir sécurisé le tangonnet avec la balancine :  
Connecter le bout-dehors à la poutre.  
La terminaison dépend du bateau  
(axe traversant / pine de tangonnet / poutre percée).

### 1 AXE TRAVERSANT :

Dans le cas d'un axe traversant, positionner d'abord l'embout arrière dans la connexion de la poutre, insérer l'axe (1), les rondelles (2), puis le sécuriser avec une goupille (3).

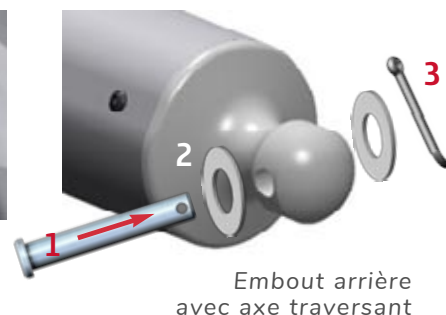

### 2 PINE DE TANGONNET :

Dans le cas d'une pine de tangonnet, dévisser **partiellement** (pour éviter qu'elles ne tombent à l'eau) les vis des deux côtés (1) & (2) de l'embout arrière. Puis insérer la pine dans l'embout arrière et resserrer les 2 vis.

*Embout arrière pour pine de tangonnet (pine non fournie)*

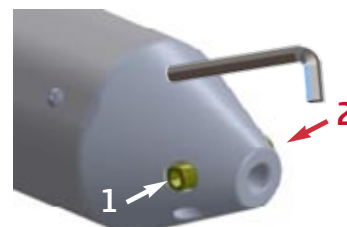

### 3 POUTRE PERCÉE :

Dans le cas d'une poutre percée, il suffit d'insérer l'embout arrière (1) dans le logement de la poutre.



## C. ACCROCHE DES SOUS-BARBES SUR LES CADÈNES & L'IBFXE

### 1 SOUS-BARBES TEXTILES - Connexion aux cadènes :

Accrocher la câble textile à la cadène puis passer à l'étape (2)

*Accroche textile sur cadène*

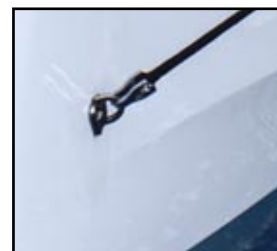

### 1bis

### SOUS-BARBES MÉTALLIQUES - Connexion aux cadènes :

Accrocher le câble sur la cadène (avec des cavaliers par exemple) puis passer à l'étape (2) et (2 bis).

*Accroche câble sur cadène*



(...) ACCROCHE DES SOUS-BARBES SUR LES CADÈNES & IBFXE

**2** SOUS-BARBES TEXTILES - Connexion à l'IB-FXE :

**IB-FXE 7000 (Axe / goupilles) :**

Engager l'axe sous barbe (1) dans la patte sous-barbes (2) en le connectant avec l'œil des estropes (3).

Mettre enfin en place la 2ème goupille fendue et l'ouvrir le plus possible (4)

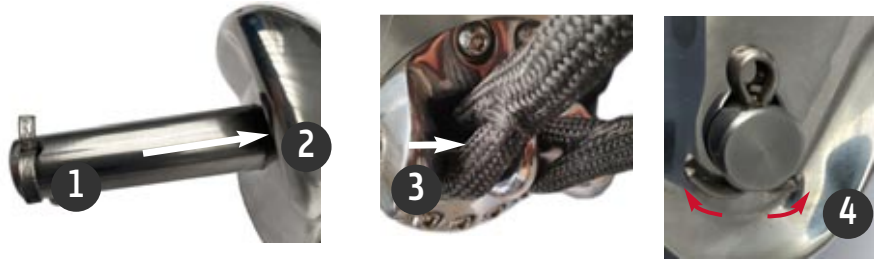

**VERSION 4500 (Axe/Vis) :** Engager l'axe sous barbe (1) dans la patte sous-barbes (2) en le connectant avec l'œil des estropes (3). Visser ensuite la 2ème vis avec du frein filet moyen (4) en s'assurant qu'elle se cale dans le lamage (5).



**2bis** SOUS-BARBES CÂBLES - Connexion à l'IB-FXE :



**D. BRANCHEMENT**

Relier le câble au boîtier relais fourni après avoir recoupé l'excédent de câble si nécessaire.



**RAPPEL :**  
Ne pas faire traîner le câble électrique au risque de l'endommager.  
Ne pas immerger le câble électrique dans l'eau de mer

Boîtier relais : voir notice ref. 29160050151 (en annexe)



> Notice boîtier relais



**RADIOCOMMANDE**



> Notice options commandes

Options commande électriques : voir notice ref. 29160050195 (en annexe)

**MISE EN PLACE DES OPTIONS**

**COMMANDE FILAIRE**



Préparer la voile en accordéon sur le pont

Vérifier au port ou mouillage la tenue de la balancine de tangonnet

Connecter avec précaution le point d'amure

Veiller à ce que la voile passe au dessus des câbles de la martingale

Accroche haute + protection

Vérification disposition drisse

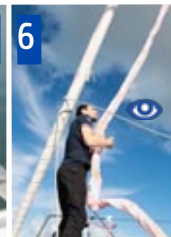
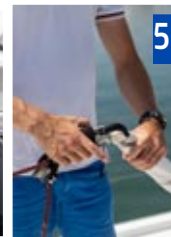
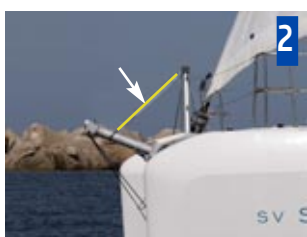

Vérification tension drisse

Piloter le déroulement en veillant aux éléments environnants

Contrôler visuellement l'enroulement et le déroulement

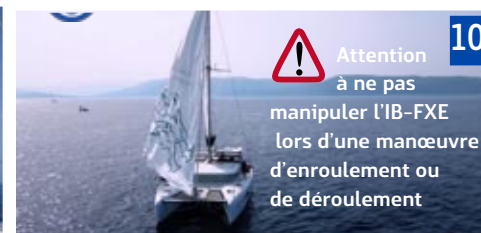

(Voir ci-dessous : "Enroulement")

## B - PRÉCAUTIONS AVANT ENVOI

- L'anticipation doit toujours prévaloir : ne déclencher la manœuvre que si les conditions le permettent et respecter rigoureusement les préconisations du voilier (polaire d'utilisation).
- être vigilant lors des manœuvres d'avant, et particulièrement pour connecter ou déconnecter le point d'amure.

## C - ENROULEMENT

- Un câble anti-torsion de qualité garantit un bon enroulement. Pour toute question, merci de consulter un revendeur
- choquer franchement l'écoute en abattant pour faciliter l'enroulement.

1 Vérifier la rectitude du guindant avant l'enroulement

2 L'écoute légèrement en tension, actionner la commande filaire ou radio-commande pour enrouler

3 Procéder par étape en gérant l'écoute pour générer un bel enroulement

4 Fin de la manœuvre. Ne pas laisser à poste si le vent monte

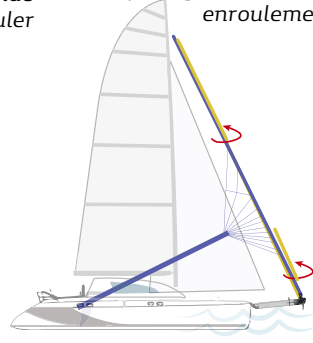
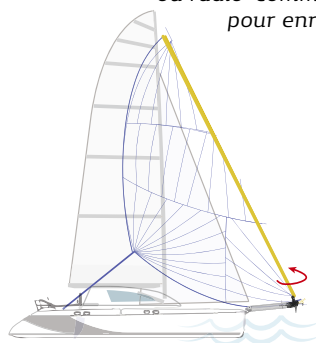
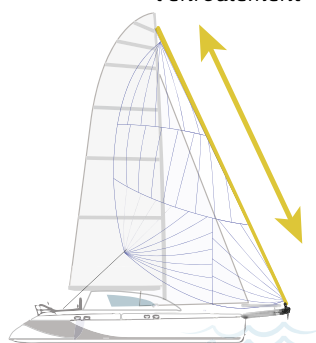

Toujours vérifier en haut si rien n'empêche l'émerillon ou la têtère de tourner librement. Une grande partie des erreurs d'enroulement se situe à ce niveau.

## D - CONNEXION VOILE / IB-FXE :

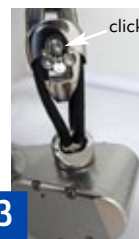

**Bas :** connecter la voile en engageant l'axe jusqu'à son verrouillage. Pour la déconnexion, appuyer sur la gachette pour sortir l'axe.

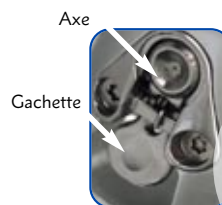

**Haut :** ouvrir l'axe gachette et connecter le haut de la voile. Repasser ensuite la housse néoprène



## E - RANGEMENT DE L'IB-FXE :

- IL EST CONSEILLÉ DE NE PAS LAISSER LA VOILE À POSTE
- Affaler la voile lorsqu'elle n'est pas utilisée et particulièrement avant les manœuvres de port pour éviter le fardage supplémentaire.

## F - ENTRETIEN :

- Rincer les mécanismes après chaque sortie.



Notre service technico-commercial ainsi que l'ensemble des revendeurs Facnor se tiennent à votre disposition pour tout renseignement ou conseil : [info@facnor.com](mailto:info@facnor.com)

**IB-FXE INSTRUCTIONS ( INSTALLATION & USE )**



**BEFORE INSTALLATION**

**1 – BOX CONTENT (to be checked upon reception)**



**A : Motorization or standard kits**



**+** Instructions manual to be kept by the user

Various configurations for bowsprit/crossbeam connection (See page 2)

**B : Necessary tools (not provided)**

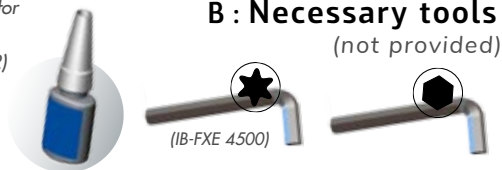

**C : Options**

	<b>Wireless remote control*</b>
	<b>Wire control*</b>
	<b>Fast Thimble 4500 &amp; 7000</b>
	<b>LB4T5 &amp; LB7T Snatch blocks</b>
	<b>Bridles attachment + wire</b>
	<b>Stropes kit for textile bridles kit</b> x2



**CAUTION :** Do not leave the electrical wire on the ground as this could damage it. Do not immerse the electrical cable in sea water.



**\* Wireless remote control & wired control :**

- The operator using the wired controller or wireless remote control transmitter is responsible for the maneuver.
- The controller must only be operated by responsible adults.
- Never press the controller button when a crew member is handling the electric drive unit.
- Be cautious of accidental button presses (e.g., when the controller is in a pocket).
- Before any sail handling, ensure it can be undertaken safely.



**Serial Number Identification**  
EX : XXXX  
N° 4 digits

**WARRANTY**

The IB-FXe product is under 2 year warranty.

Ref. 29160080004 - Rev B 10/2024

## A. BOWSPRIT HOLDING (“WHISKER POLE”)

Add a topping lift (to hold the bowsprit) between top of the cathedral and the shackle of the bowsprit.

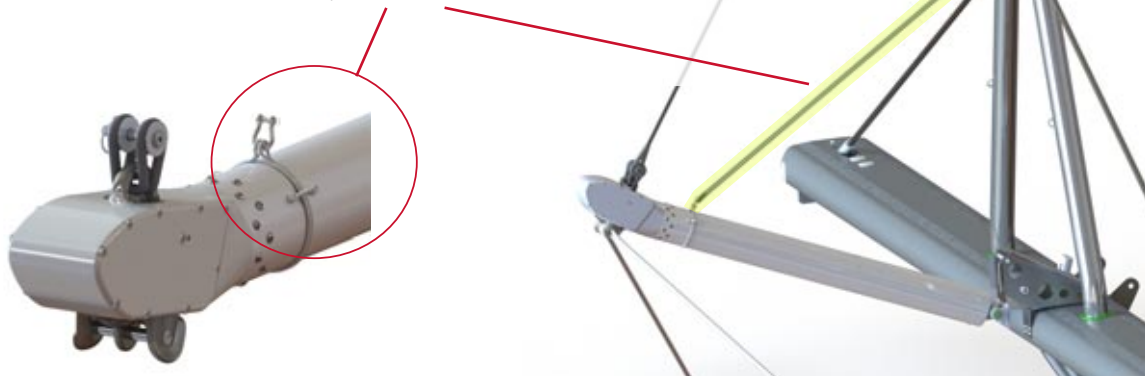

## B. CONNECTION TO THE CROSSBEAM

After securing the whisker pole with the swing:  
Connect the bowsprit to the beam.  
The end depends on the boat  
(thru axis / whisker pole pin / holed beam).

### 1 THRU PIN:

In the case of a thru pin, first position the rear end in the beam connection, insert the pin (1), the washers (2), then secure it with a split pin (3).

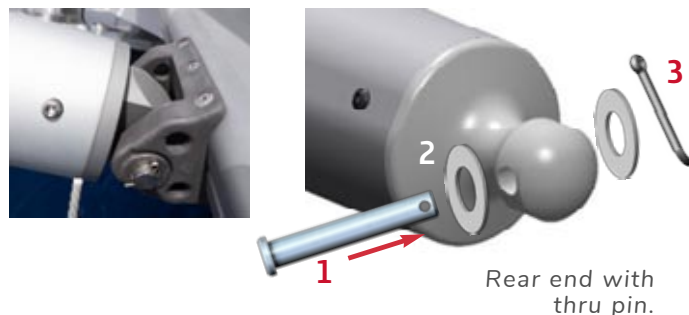

### 2 WHISKER POLE PIN :

In the case of a whiskerpole pin, **partially** unscrew (to prevent them from falling into the water) the screws on both sides (1) & (2) of the rear tip. Then insert the pin into the rear end and tighten the 2 screws.

*Rear tip for whiskerpole pin (pin not supplied)*

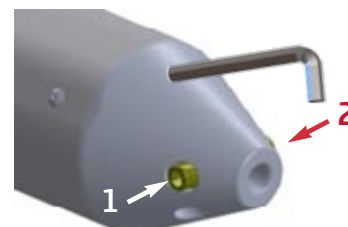

### 3 HOLED BEAM :

In the case of a holed beam, simply insert the rear end (1) into the beam housing.



## C. ATTACHMENT OF THE BRIDLES ON THE PADEYES & IBFXE

### 1 TEXTILE BRIDLES - Connection to the padeye :

Hook the textile cable to the padeye then proceed to step (2)

*Textile attachment on padeye*

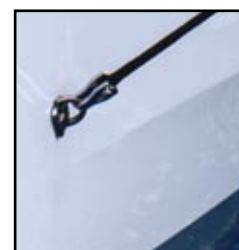

### 1bis

### WIRE BRIDLES- Connection to the padeye :

Hook the wire to the padeye (with double jaw toggle for example) then go to step (2) then (2 bis) .

*Wire attachment on padeye*



(...) ATTACHMENT OF THE BRIDLES ON THE PADEYE & IBFXE

**2** TEXTILE BRIDLES - Connection to the IB-FXE :

**IB-FXE 7000 (Pin / split pins) :** Engage the bridle axis (1) in the bridle attachment (2) by connecting it with the eye of the stropes, (3). Finally, put the 2nd split pin in place and open it as much as possible (4)

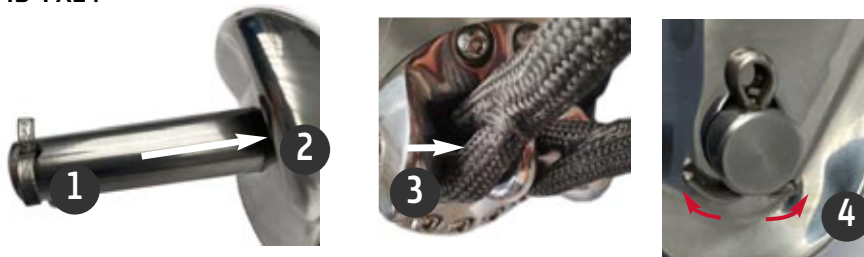

**4500 VERSION (Pin/screw) :** Engage the bridle axis (1) in the bridle attachment (2) by connecting it with the eye of the stropes, (3). Then screw in the 2nd screw with blue threadlocker (4) making sure that it fits into the countersink (5).

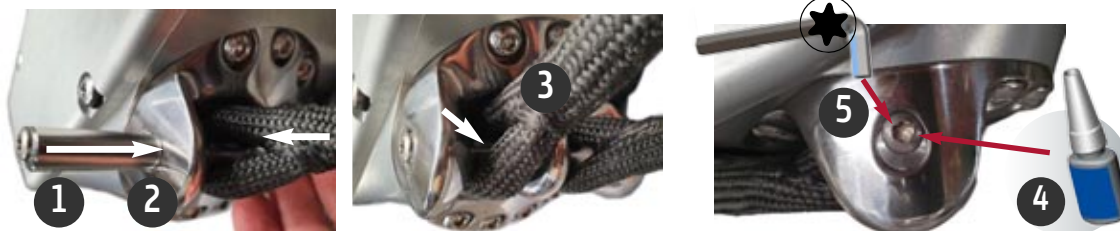

**2bis** WIRE BRIDLES  
Connection to the IB-FXE :



**D. ELECTRIC CONNECTION**

Connect the cable to the relay box provided after cutting the excess cable if necessary.

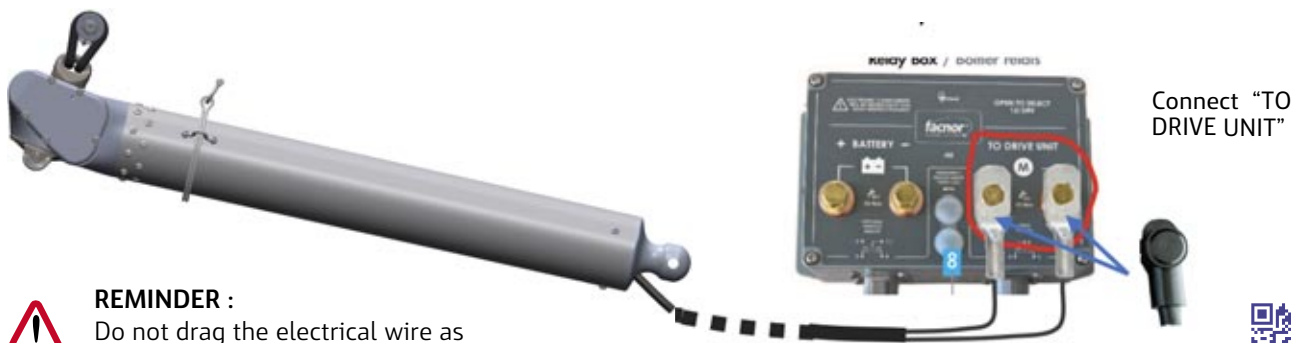

**⚠ REMINDER :**  
Do not drag the electrical wire as this could damage it.  
Do not immerse the electrical wire in sea water

Relay box : see instructions ref. 29160050151 (in appendix) > [Relay box instructions](#)

**OPTIONS INSTALLATION**

**WIRELESS REMOTE CONTROL**



> [Remote control instructions](#)

Electric remote control options : see instructions ref. 29160050195 (in appendix)

**WIRED CONTROL**



Lay the sail on deck



Check the holding of the whisker pole in harbour or anchorage



Carefully connect the tack



Ensure that the sail passes through above the martingale cables



Connect the top mechanism + protection



Checking the halyard layout



Check the halyard tension



Unfurl the flying sail while watching the environment



Visually check when furl-in or furl-out



(See below : "Furling")

**B - HOISTING PRECAUTIONS**

- Always anticipate the sail handling : start it conditions permitting and rigorously respect the sail use range specified by the sailmaker (use range)
- be vigilant during forward maneuvers, and particularly when connecting or disconnecting the tack.

**C - FURLING**

- The anti-torsion quality of the luff rope ensures the furling efficiency. For any enquiry, please contact one Facnor dealer
- Release well the sheet while sailing further downwind for easier furling.

**1** Tighten the tension into the luff before furling



**2** Slightly tighten the sheet, then press the wireless remote control - or wired control button to furl in

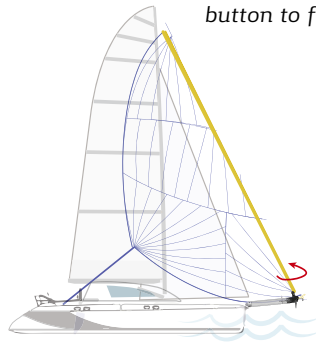

**3** Progressively release the sheet so that the sail furls in properly

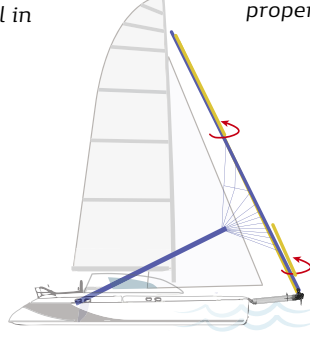

**4** End the handling. Do not leave the sail hoisted if the wind rises



Always check if anything prevents the top swivel or the head of the sail from free rotation. Most failed sail handling come from there.

**D - SAIL / IB-FXE CONNECTION :**



**Bottom :** connect the sail by engaging the pin until it locks. To disconnect, press the trigger to extract the pin.

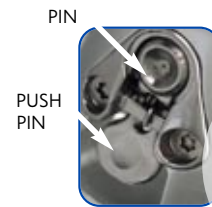

**Top :** open the trigger pin and connect the top of the sail. Then fit the protection cover



**E - IB-FXE STORAGE :**

- IT IS ADVISED NOT TO KEEP THE SAIL ALWAYS HOISTED
- Lower the sail when not in use and particularly before manoeuvring in the harbour to avoid the additional windage.

**F - MAINTENANCE :**

- Rinse with clear water the mechanisms after every use



Please do not hesitate to contact Facnor sales team or agents if you have any queries : [info@facnor.com](mailto:info@facnor.com)