

The Facnor mainsail furling system makes your sailing safe and comfortable. No more effort to reef the sail in choppy seas : you will always have the right area of sail adapted to the wind conditions. No more folding or flaking the sail: with simple handling, your mainsail is quickly furled or unfurled. Your boat will always be ready to leave with sails already set up.

SIMPLE INSTALLATION & COST EFFECTIVE

Compact F

- Safe handling of the mainsail
- Installation without modifying or drilling the mast
- This system allows keeping the original goose neck
- Simple to use
- Excellent quality/price ratio compared with other mainsail furler systems



Drive unit

- The furling sections turns by operating the drive unit with a continuous line system.
- The drive unit is fitted with two sets of stainless steel ball bearings and fixed to the mast above the goose neck with slugs

Original Gooseneck

This system allows keeping the original gooseneck



Furling sections (2 meters long)

They fit inside the housing sections. The sail is furled round them.

Halyard swivel

Housing sections (=1,7 meters long)

fixed with slugs to the mast + PVC strips.



Bottom sections design

- The section design prevents damaging the sail.
- The edges of the housing section incorporate a round groove so that a spare sail or protection strip can be hoisted.

Mainsail without batten

Boom equipment

Two versions available :
 - "standard" and "special" - allows perfect positioning of the clew. (see against p. 51).





CF MODEL SELECTION

Range of mainsail furling systems suitable for 6 to 17 meter sailing boat. The chart below allows to determine the model that suits your boat (please ask for advice to our dealers).

Parameters	CF MAINSAIL FURLER RANGE							
	CF80				CF105			
CF Mainsail furler reference	4CF 80	5CF 80	6CF 80	7CF 80	7CF 105	8CF 105	9CF 105	10CF 105
Maximum luff length (meters-feet)	6,80 22'	8,50 28'	10,20 33'	11,90 39'	11,90 39'	13,60 45'	15,30 50'	17,00 56'
Maximum boom length (meters-feet)	3,90 m 12'				6 m 20'			
Housing section weight (kg)	1,850 kg				3,030 kg			
Furling section ø (mm - ft)	30 mm - 1"3/4							

Simplicity in the design :

A furling system that turns a headsail inside housing sections. The drive unit of the sections is situated just above the goose neck and is operated with a continuous furling line (Facnor patent).

Simplicity of installation & strong fixing :

The housing sections are fixed with slugs alongside the mast (drilling not necessary). The drive unit is easy to install and does **not require any modification to the gooseneck**. This kit is suitable for most of the masts and is quickly fitted without unstepping the mast. The CF mainsail furling system is produced using high tech means.

SIMPLE INSTALLATION ON THE MAST

Easy fixing of the housing sections :

- fitted to the mast by inserting slugs inside the mast groove (see p.48);
- housing sections and slugs fixed together by stainless steel screws and Nylock nuts;
- pre-drilled.



Housing and furling sections

- Resistance and lightness : These sections are made of extruded aluminium and anodised after machining;
- The furling sections are twin groove;
- standard length = 1,70 M.



(fig 1)



(fig 2)

BOOMS KITS : STANDARD & SPECIAL

Booms kit configurations

- RC80 & RC 105 standard version (standard delivered) (Fig.1): track on which a ball bearing car fitted with a shackle.

Track installation : with slugs, like the housing sections

- optional : KB80 & KB105 special version (Fig. 2) with additional sheaves system :

Complete kit = 1 ball bearing car fitted with a pivoting sheave + 2 needle bearing sheaves (1 front and 1 back) + 1 special end stop.

This KB version allows not to use the boom sheaves, often inadequate due to their small diameter and their lack of ball bearings or needles



CF DIMENSIONS

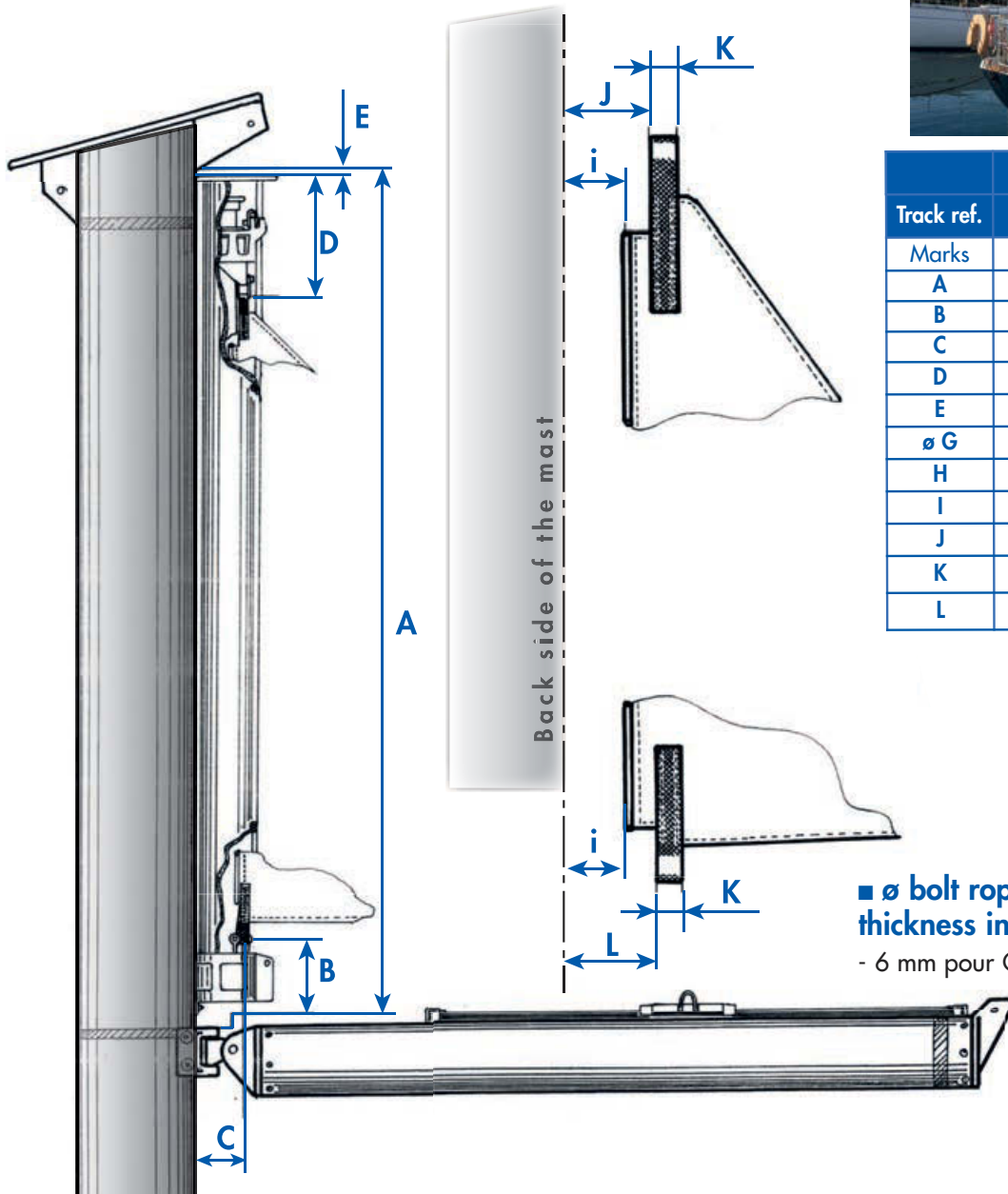

Track ref.	CF Model	
	CF 80	CF 105
Marks	Dimensions (mm)	
A	*	*
B	140	140
C	65	85
D	190	210
E	50	70
∅ G	7	7
H	10	10
I	65	75
J	75	85
K	20	20
L	75	85

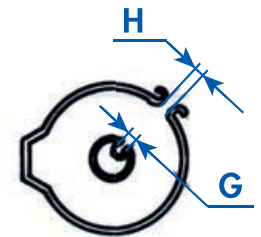

■ ∅ bolt rope (mainsail luff tape thickness included) :
- 6 mm pour CF 80 & CF 105

TECHNICAL SUPPORT

Instructions for Headsail furlings & reefing systems, Gennaker & Code zero furlers, Facslide+, Mainsail furlers, former ranges,...

Most of the installation manuals are available on our web site pro support. However, the best pro support you can get is the support of our experienced and skilled dealers who will be able to advise you according to your sailing program and your boat.

Caution : The specified technical datas are likely to be amended. Therefore, Facnor reserves the right to modify those datas at any moment following product development.

Consult the Facnor instructions on our technical support



NEWS & VIDEO SUPPORT

Installation of Facnor equipment, use, product information :

NEWS & VIDEOS
JOIN US ON
fb.me/FacnorFurlingSystems

